

Issue Date: 11-02-2016
Revision Date: 11-30-2018
Renewal Date: 11-02-2019

DIVISION: 06 00 00 – WOOD, PLASTICS AND COMPOSITES
Section: 06 63 00 – Plastic Railings

REPORT HOLDER:

American Choice Railing and Fencing LLC
5005 Belmar Blvd. Suite A-1
Wall Township, NJ 07727
732-793-1765
www.AmericanChoiceRailings.com

REPORT SUBJECT:

Vinyl T-Rail System

1.0 SCOPE OF EVALUATION

1.1 This Research Report addresses compliance with the following Codes:

- 2018, 2015 and 2012 *International Building Code*® (IBC)
- 2018, 2015 and 2012 *International Residential Code*® (IRC)

NOTE: This report references 2018 Code sections with [2015 and 2012] Code sections shown in brackets where they differ.

1.2 Vinyl T-Rail System has been evaluated for the following properties:

- Structural Performance
- Durability
- Surface Burning
- Termite Resistance
- Decay Resistance.

1.3 Vinyl T-Rail System has been evaluated for the following uses (see Table 1):

- The Vinyl T-Rail System is a guard or guardrail under the definitions of the referenced codes. It is intended for use at or near the open sides of elevated walking areas of buildings and walkways as required by the codes.

- Guardrail systems recognized in this report may be used in One- and Two-Family Dwellings regulated by the IRC and all construction types regulated by the IBC in accordance with IBC Section 705.2.3.1 [1406.3], Exception 2. See Table 1 for additional restrictions based upon Use and Occupancy Classification.

2.0 STATEMENT OF COMPLIANCE

Vinyl T-Rail System complies with the Codes listed in Section 1.1, for the properties stated in Section 1.2 and uses stated in Section 1.3, when installed as described in this report, including the Conditions of Use stated in Section 6.

3.0 DESCRIPTION

3.1 Materials and Processes – The *Vinyl T-Rail System* is an assemblage of extruded and molded components utilizing Poly Vinyl Chloride (PVC) material and aluminum reinforcements. See Figure 1 for assembly. The system consists of the following components:

3.1.1 The PVC top rail, T-Rail, are extruded PVC at 0.09 inches thick with a profile having overall dimensions of 3.5" wide by 3.5" tall. See Figure 2.

3.1.2 The PVC Baluster in the system are extruded 0.07" thick PVC square profile having overall dimensions of 1.5" wide by 1.5" tall. See Figure 3.

3.1.3 The PVC Bottom rail are extruded .095" thick PVC rectangular shape profile having overall dimensions of 2.0" wide by 3.5" tall. See Figure 4.

3.1.4 Full length extruded aluminum 6063-T6 inserts provide reinforcement for both the top and bottom rails of the referenced railing system. See Figure 5.

3.1.5 Top and bottom rails are attached to the conventional 4x4 wood posts. The top and bottom attachment is made utilizing a straight PVC molded bracket socket which is secured to the post and rail. See Figure 6.



3.1.6 A non-structural PVC post sleeve can be provided as a cladding over conventional 4x4 wood posts. See Figure 7.

4.0 PERFORMANCE CHARACTERISTICS

4.1 The American Choice LLC Guardrail System described in this report have demonstrated the capacity to resist the design loadings specified in Chapter 16 of the IBC, and Section R301 of the IRC, when tested in accordance with ICC-ES AC174.

4.2 Structural Performance has been demonstrated for a temperature range from -20° F to 125° F.

4.3 Materials used are deemed equivalent to preservative treated or naturally durable wood for resistance to weathering effects, decay and attack from termites

4.4 Materials used have a flame spread index not exceeding 200 when tested in accordance with ASTM E 84.

5.0 INSTALLATION

5.1 General:

Vinyl T-Rail must be installed in accordance with the manufacturer's published installation instructions, the applicable Code, and this Research Report. A copy of the manufacturer's instructions must be available on the jobsite during installation.

5.2 Application:

5.2.1 Guardrails are attached to supports with PVC brackets that use self-drilling screws. See Table 2 for the fastening schedule and Figure 5 for bracket detail.

5.2.2 Railing systems may be attached to conventional wood posts or other suitable wood support structures. Wood in supporting structure shall have a specific gravity of 0.50 or greater (Southern Yellow Pine or better) and a minimum thickness to allow full penetration of the bracket mounting screws. Conventional wood posts or other wood supports are not within the scope of this report.

6.0 CONDITIONS OF USE

6.1 Installation must comply with this Research Report, the manufacturer's published installation instructions, and

the applicable Code. In the event of a conflict, this report governs.

6.2 Conventional wood guardrails supports including 4x4 posts, and framing are not within the scope of this report and are subject to evaluation and approval by the building official. Conventional wood posts and structural support framing for post installations must satisfy the design load requirements specified in the Chapter 16 of the building code and must provide suitable material for anchorage. Where required by the building official, engineering calculations and details shall be provided.

6.3 Installation must comply with this Research Report, the manufacturer's published installation instructions and the applicable Code. In the event of a conflict between the manufacturer's instructions and this report, this report governs.

6.4 Only those types of fasteners and fastening methods described in this report have been evaluated for installation of the Vinyl T-Rail system; other methods of attachment are outside the scope of this report.

6.5 Compatibility of fasteners, brackets and other metallic components with the supporting structure, including chemically treated wood, is not within the scope of this report.

6.6 All products are manufactured by American Choice Railings and Fencing LLC.

6.7 The Vinyl T-Rail is manufactured under a quality control program with inspections by Intertek Testing Services NA, Inc.

7.0 SUPPORTING EVIDENCE

7.1 Manufacturer's drawings and installation instructions.

7.2 Reports of testing in accordance with ICC-ES AC174, Acceptance Criteria for Deck Board Span Ratings and Guardrail Systems (Guards and Handrails), Revised December 2014.

7.3 Reports of testing and engineering analysis demonstrating compliance with the performance requirements of ASTM D 7032-14 [-10a, 08], Standard Specification for Establishing Performance Ratings for





Wood-Plastic Composite Railing and Guardrail Systems (Guards or Handrails).

7.4 Documentation of an Intertek approved quality control system for the manufacturing of products recognized in this report.

8.0 IDENTIFICATION

The Vinyl T-Rail is below, and the Code Compliance Research Report number (CCRR-0246).



9.0 OTHER CODES

This section is not applicable.

10.0 CODE COMPLIANCE RESEARCH REPORT USE

10.1 Approval of building products and/or materials can only be granted by a building official having legal authority in the specific jurisdiction where approval is sought.

10.2 Code Compliance Research Reports shall not be used in any manner that implies an endorsement of the product by Intertek.

10.3 Reference to the <https://bpdirectory.intertek.com> is recommended to ascertain the current version and status of this report.

This Code Compliance Research Report ("Report") is for the exclusive use of Intertek's Client and is provided pursuant to the agreement between Intertek and its Client. Intertek's responsibility and liability are limited to the terms and conditions of the agreement. Intertek assumes no liability to any party, other than to the Client in accordance with the agreement, for any loss, expense or damage occasioned by the use of this Report. Only the Client is authorized to permit copying or distribution of this Report and then only in its entirety, and the Client shall not use the Report in a misleading manner. Client further agrees and understands that reliance upon the Report is limited to the representations made therein. The Report is not an endorsement or recommendation for use of the subject and/or product described herein. This Report is not the Intertek Listing Report covering the subject product and utilized for Intertek Certification and this Report does not represent authorization for the use of any Intertek certification marks. Any use of the Intertek name or one of its marks for the sale or advertisement of the tested material, product or service must first be approved in writing by Intertek.





TABLE 1 - PROPERTIES EVALUATED

Guardrail System	Maximum Guardrail Dimensions ¹	Guardrail Type	Baluster	Code Occupancy Classification
Vinyl T-Rail	8 ft. (96 in.) by 42 in.	Level / In-Line Application	1 ½" x 1 ½" Square PVC	IBC one- and two-family dwellings only and, IRC
	10 ft. (120 in.) by 36 in. (Support Block required)	Level / In-Line Application		IRC Only

TABLE 2 – FASTENING SCHEDULE

Connection	Fastener
Top Rail Bracket to Post	Six #10-10 x 1-1/2" (0.117 in minor diameter) self-drilling, Phillips drive, pan-head, coated carbon steel screws
Bottom Rail Bracket to Post	Four #10-10 x 1-1/2" (0.117 in minor diameter) self-drilling, Phillips drive, pan-head, coated carbon steel screws
Top/Bottom Rail Bracket to Rail	Two #10-12 x 1" (0.137 in minor diameter) self-drilling, Phillips drive, pan-head, coated carbon steel screws
Support Block to Deck Surface	One #10-12 x 3/4" (0.129 in minor diameter) Type A point, Phillips drive, pan-head, stainless steel screw
Support Block to Support Block (Height Adjustment)	
Support Block to Bottom Rail	
Baluster to Top/Bottom Rail	Slip fit - No Mechanical Connection

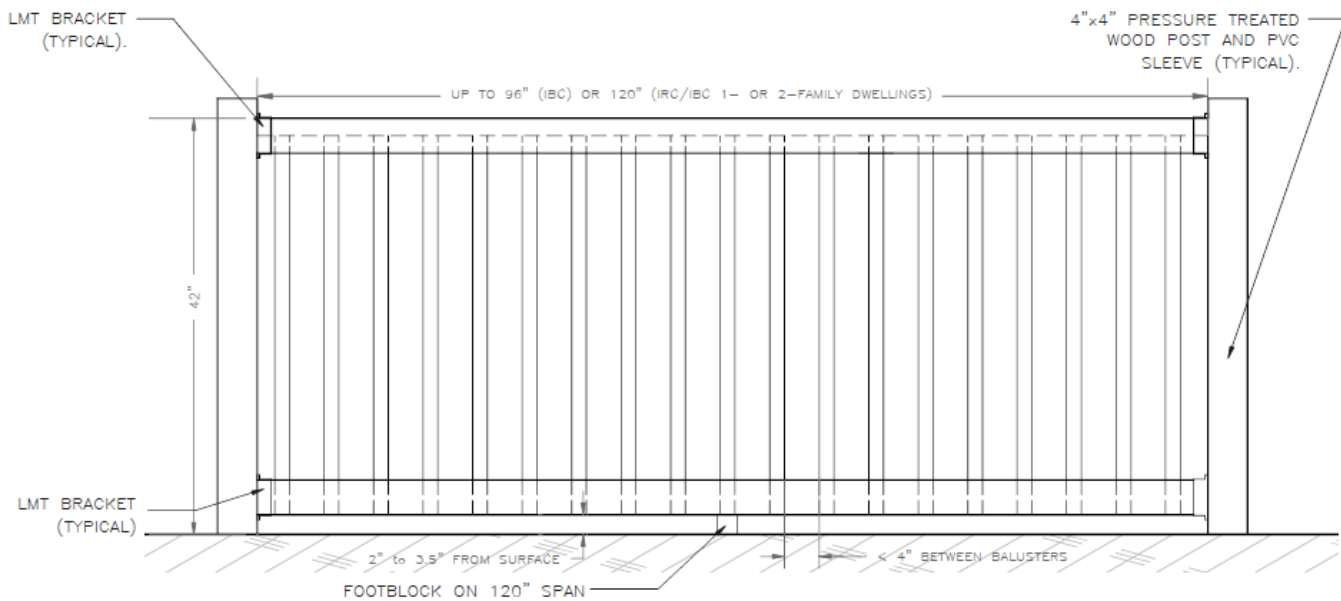

FIGURE 1 - Rail Assembly

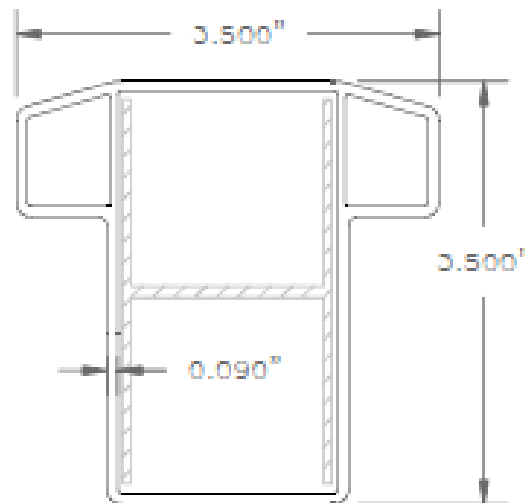

FIGURE 2 -Top Rail Profile

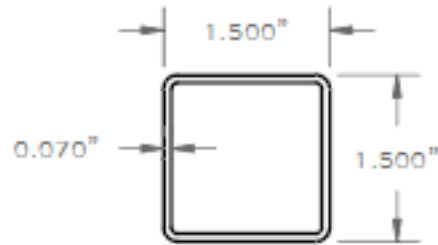

FIGURE 3 – Baluster

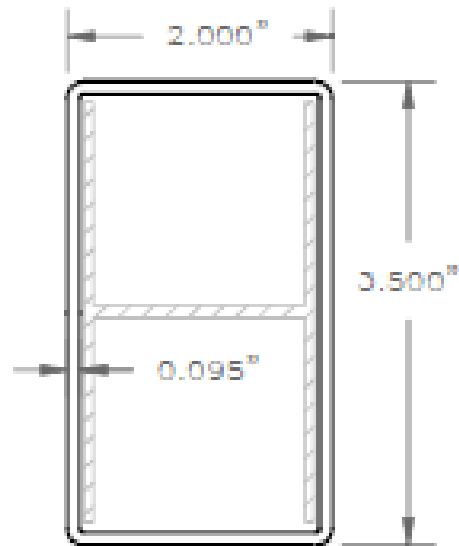

FIGURE 4 - Bottom Rail Profile

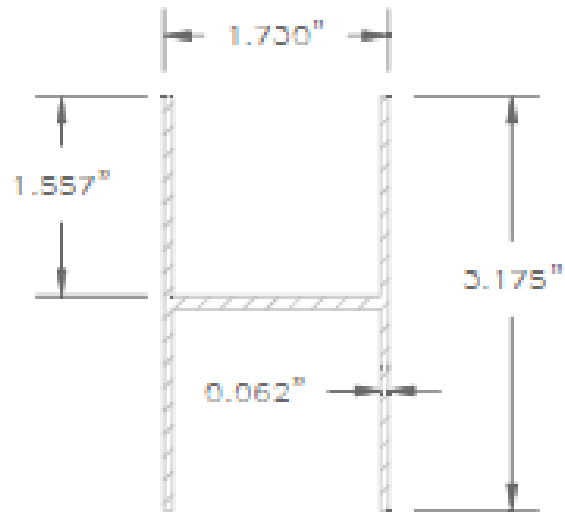

FIGURE 5 – Aluminum Insert

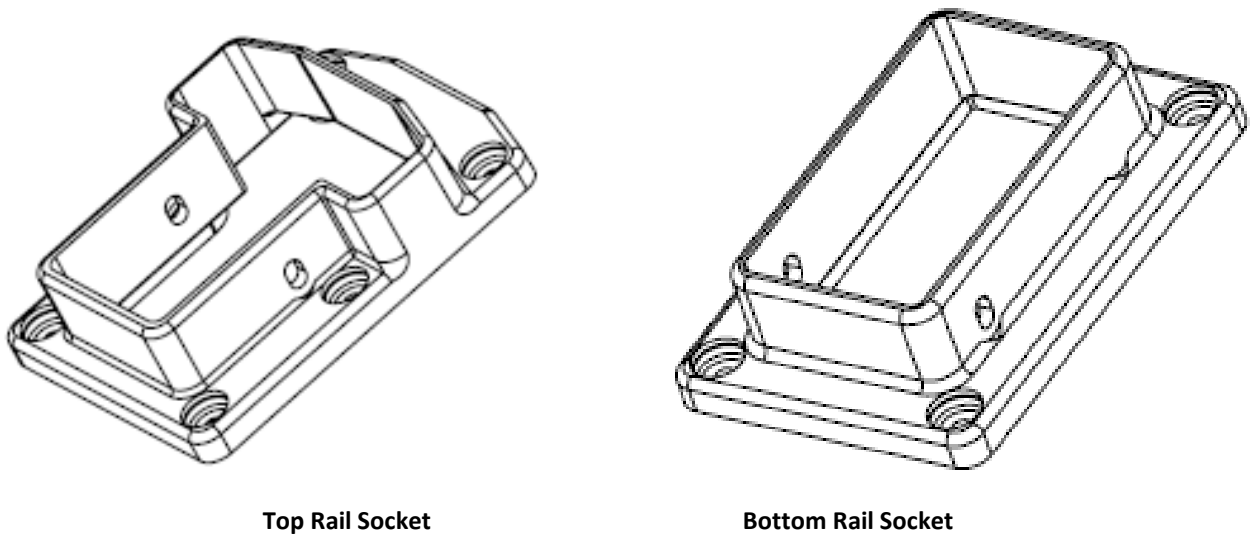

FIGURE 6 – Rail to Post Connections

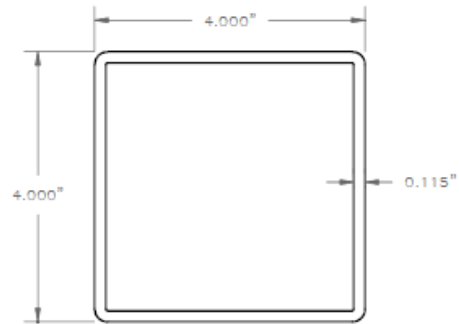

FIGURE 7 – Post Sleeve

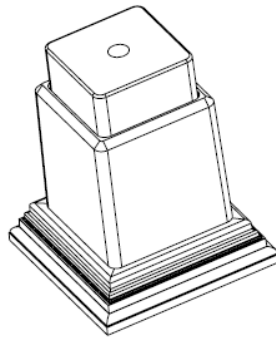

FIGURE 8 – Support Block